



SPARTAN WATER

5 kW | Diesel Heater

Power:	1500-5000 W (5,100-17,000 BTU)
Fuel:	Diesel, HVO
Operating Voltage:	12 V DC
Fuel Consumption:	0,16-0,5 l/h (5.4-16.9 oz/hr)
Electricity Consumption:	0,5-1,2 A
Weight:	10,6 kg / 23 lbs.



New Wallas Spartan Water is a water heating system, which can be used solely for heating domestic fresh water or it can also be used to power up floor and radiator heating. Underfloor heating provides a consistent temperature profile around the cabin and the warm feeling when your bare feet are in direct contact with the floor. High levels of moisture and humidity at floor level can often be a breeding ground for dust mites and mold, but switching to an underfloor heating system allows you to drastically improve the hygiene all around. Additionally, Spartan Water can be turned on remotely with the Wallas App even from the comfort of your home, which saves a tremendous amount of time. Spartan Water is an excellent option for other off-grid applications as well, for instance, camper vans, cottages, office/break room containers, or construction trailers.



3009 ADVANCED

THERMO | Intelligent Control Panel

- The **Thermostat Mode** automatically keeps the room at an even temperature
- **Summertime Mode** allows you to heat only the hot shower water system without heating the space
- The simple display shows all relevant information at one glance
- Both coolant and hot water targets can be set separately

Small solar panel charges the 12 V battery.

Spartan Water heats up the fresh water tank providing hot water even in distant off-grid locations.

12 V battery as a power source.

With a second water pump installed, Spartan Water can also be used for underfloor and radiator heating.

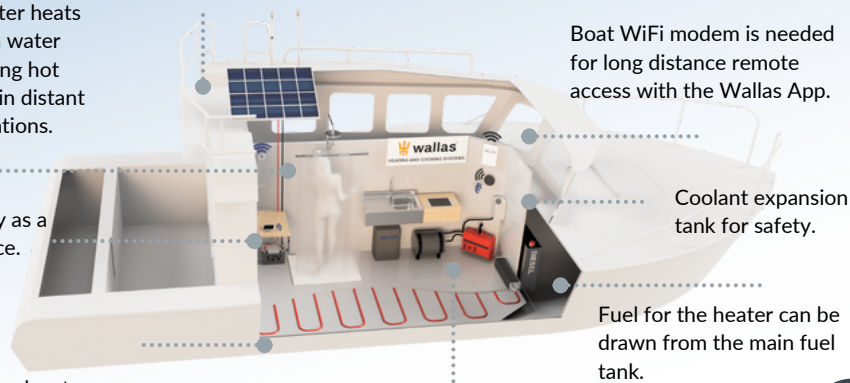

Boat WiFi modem is needed for long distance remote access with the Wallas App.

Coolant expansion tank for safety.

Fuel for the heater can be drawn from the main fuel tank.

Coolant circulation hoses heat water in the hot water tank.

Energy-efficient

Low Running Costs

Ultra-low Emissions

Better Indoor Air Quality

INSTALLATION

Easy installation can be done independently or by a Wallas professional.

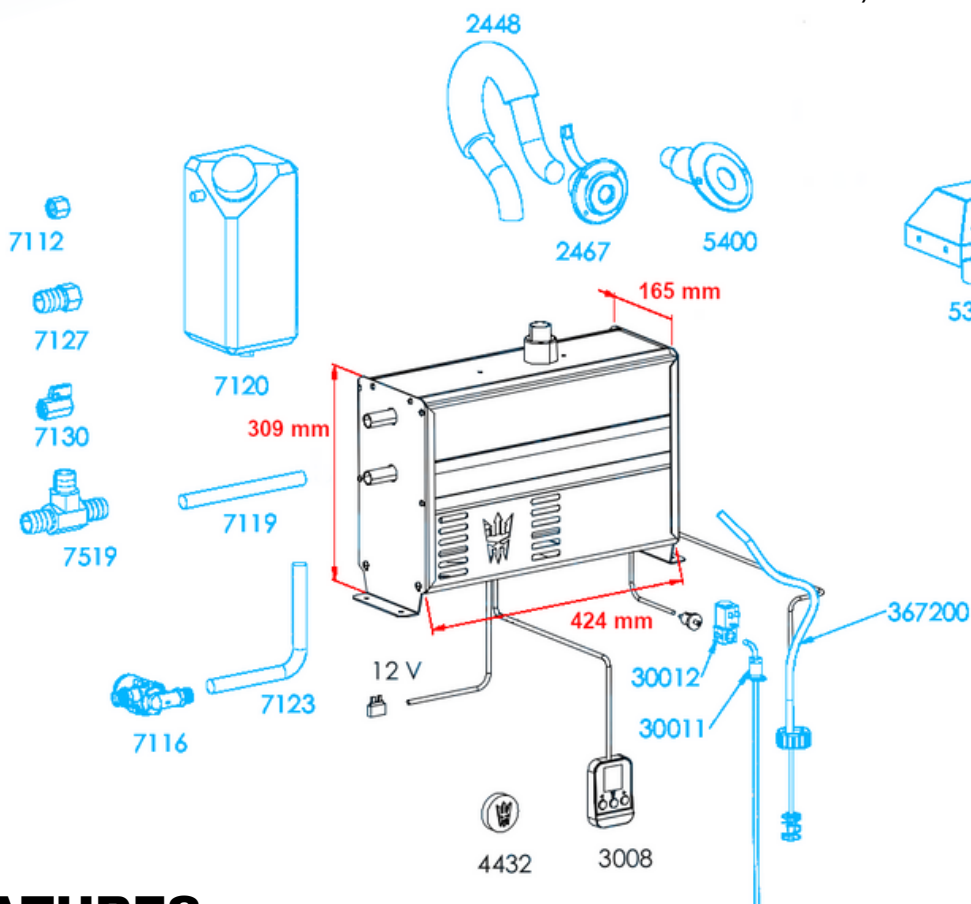

Wireless temperature sensor monitors cabin temperature with improved accuracy and flexibility.

Recommended Builds

Boats: 9-12 m (29-40 ft)
Camper Vans: MB Sprinter
Trailers: up to 8 m (26 ft)

FEATURES

- Advanced Control Panel enables intelligent temperature control.
- Wireless temperature sensing for improved accuracy.
- Fully enclosed laminar combustion is a safe burning process with no exposed flame.
- Delivers heat to a hot water tank and/or floor and radiator heating.
- Floor heating dispenses even heat to the indoor space and provides the added comfort of warm floors under your feet.
- No burning hot heater grilles for everyone's safety.
- Brushless motors have a very long life-cycle, supporting reliably long service intervals.
- Made of stainless steel, high-grade aluminum, and other corrosion-resistant materials.
- Warranty 2+1 years.
- E-mark approved for vehicles.



Accessories in black come with the standard package. Accessories in blue are additional/optional. Wallas-Marin reserves the right to change or improve its products and to make changes in the content of this brochure without obligation to notify any person or organization of such changes or improvements. Go to www.wallas.fi for current updates and supplemental information concerning these products.

wallas.fi