

85 DT

CERAMIC | Forced Air Marine Stove



The Greenboost burner burns renewable fossil-free diesel cleanly and energy-efficiently, as well as fossil based diesel fuel.

Exhaust gas is safely expelled outside keeping the indoor air clean and odorless.

Fully enclosed laminar burning process ensures a quiet sound level and dries the indoor air.



Brushless blower motors have a very long life-cycle, supporting reliably long service intervals.

Feeding fuel directly from the main tank of the vessel saves space and eliminates the need for a separate tank.

Durable Finnish design and manufacturing keep your Wallas running through tough weather conditions.



Flush mount aluminum edges are only 2 mm above the surface of the counter.

Laminar combustion is a safe burning process with no exposed flame.

Unlike propane stoves, diesel stoves do not require gas inspections.

Left plate is for boiling - right side for simmering.

85 DT

CERAMIC | Forced Air Marine Stove



SPECIFICATIONS

Fuel:	Diesel
Power:	900-1900 W (3,000-6,400 BTU)
Operating voltage:	12 V
Fuel consumption:	0,09-0,19 l/h (3.16-6.4 oz/hr)
Electricity consumption:	0.2-0.35 A
Colors:	Stainless steel, black



PI THERMO CONTROL PANEL

Ceramic cooktop is easy to operate with a power knob similar to domestic stoves.



KETTLE HOLDERS

Kettle holders (accessory 1110) keep cookware safely in place.

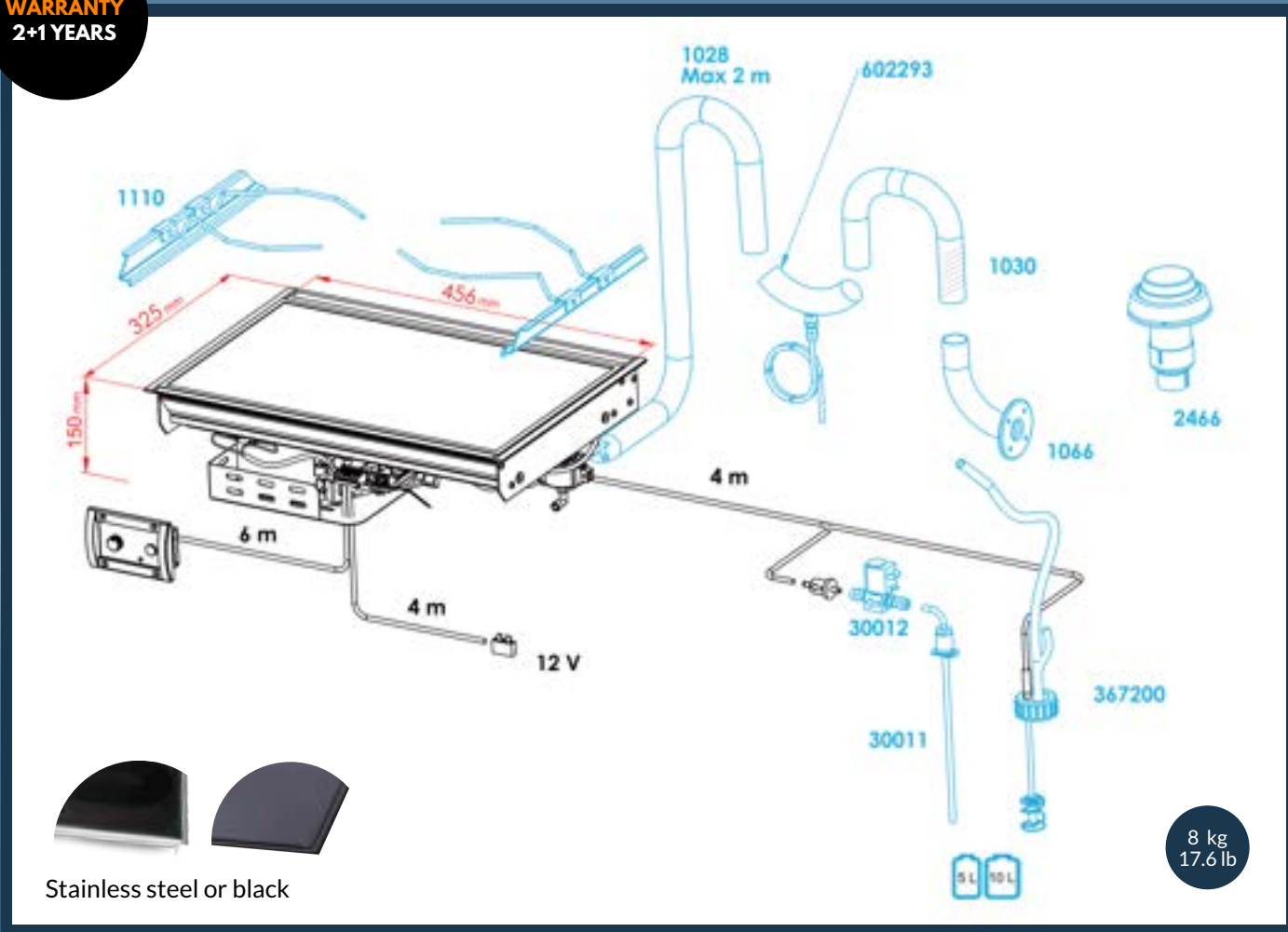

Accessories in black come with the standard package. Accessories in blue are additional/optional. The calculated values are measured in a reference measurement wall, which is constructed to represent a typical boat installation. The figures allow for 10 % reserve - yours may vary.

All rights reserved. Wallas-Marin reserves the right to change or improve its products and to make changes in the content of this product material without obligation to notify any person or organization of such changes or improvements. Go to www.wallas.com for current updates and supplemental information concerning this product.



www.wallas.com