



powered by **ARCO**
EST. 1960



**HIGH ENERGY
ALTERNATOR REGULATOR**

**Lithionics Battery RV-C
Integration Guide**





PHYSICAL CONNECTION



Use Lithionics CAN harness 75-532-60, or another compatible harness to merge Lithionics BMS and Zeus on the same CAN network.

WIRING DIAGRAM

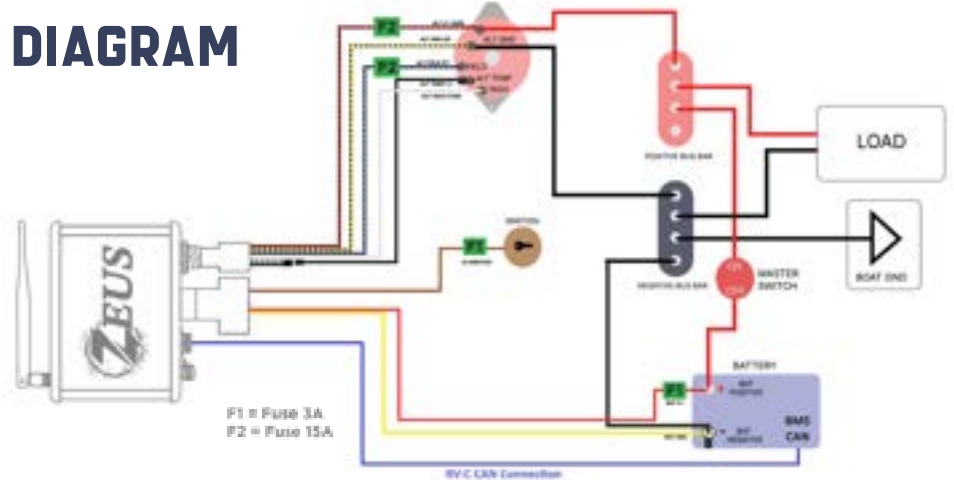

ZEUS CONFIGURATION

1. In the ARCO App, connect to your Zeus and click 'View Device.'
2. Select 'Live Details.'
3. Select 'Settings.'
4. Select 'Regulator' tab.



5. Scroll down until you see 'Sync Mode' and click on the text, then select 'Lithionics Follower.'
6. With 'Lithionics Follower' mode selected, save your changes.



Zeus is now configured!

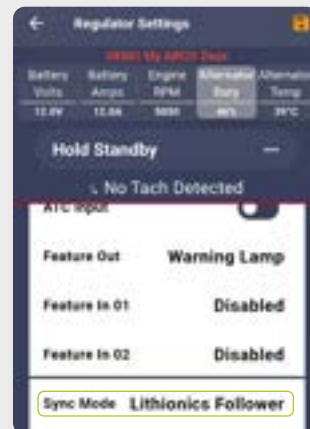



CERBO GX CONFIGURATION



1. Under 'Settings' select 'Services'.
2. Select 'VE.CAN port'.
3. For the 'CAN-bus profile' select the option for 'RV-C (250 kbit/s)'.

The Cerbo is now configured!

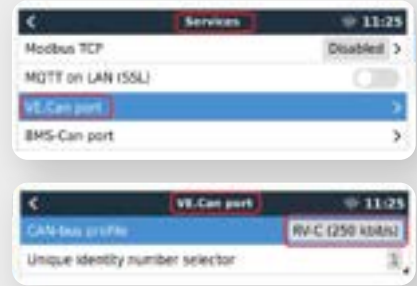

NETWORK DIAGRAM

